

Accessories

Mounting Brackets

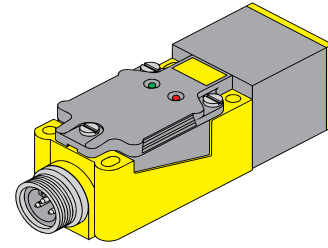
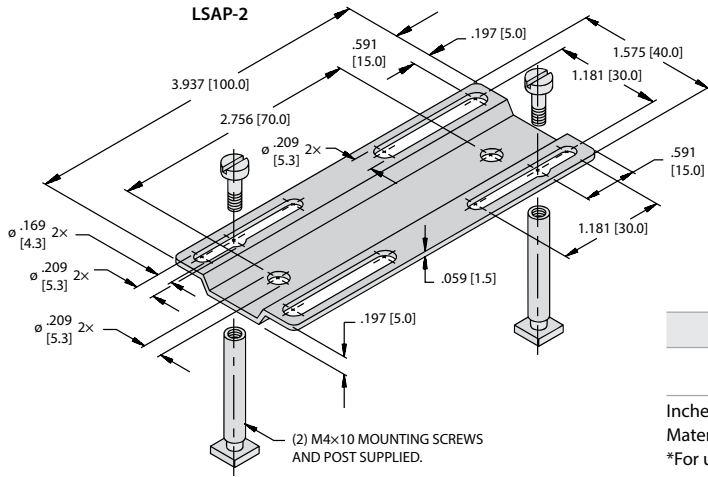

Part Number	ID Number
LSAP-2	M6942900

Inches [mm]
 Material: Stainless steel
 *For use with CP40

We reserve the right to make technical alterations without prior notice.

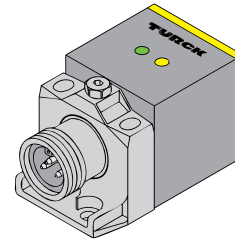
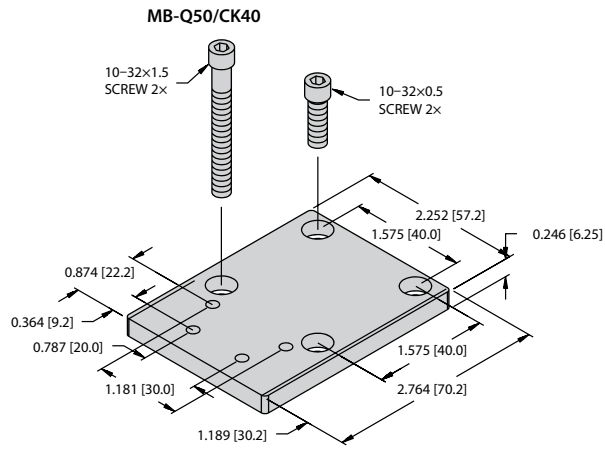

Part Number	ID Number
MB-Q50/CK40	A3148

Inches [mm]
 Material: Stainless steel
 *For use with Q50 or CK40 sensors

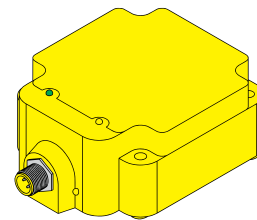
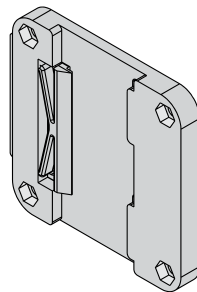
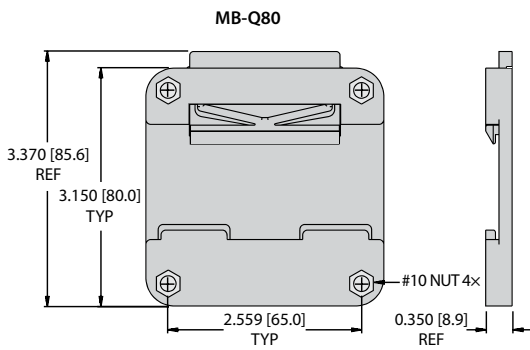

Part Number	ID Number
MB-Q80	A3144

Inches [mm]
 Bracket Material: Plastic
 Insert Material: Stainless steel
 *For use with Q80 sensors